

USER MANUAL

# ABBNEY ROAD TWO ICONIC STRINGS PROFESSIONAL

SPITFIRE AUDIO

# CONTENTS

INTRODUCTION	3
WELCOME	4
DOWNLOADING & INSTALLING	5
THE SPITFIRE APP PREFERENCES	6
THE DEDICATED PLUGIN	7
HAVE A LOOK AROUND	8
MAIN CONTROLS	12
SIGNAL MIXER	13
TECHNIQUE SELECTOR	15
EFFECTS	17
ARRANGER	18
TECHNIQUE EDITOR	20
TOP MENU	21
MICROPHONE SIGNALS	25
MICROPHONE GROUPING	26
TECHNIQUES	27
APPENDIX A — FAQs AND TROUBLESHOOTING	29
APPENDIX B — TECHNIQUES/MICS/MIXES	33
APPENDIX C — DEFAULT CC MAPPINGS	34

# INTRODUCTION

Abbey Road Two: Iconic Strings represents something truly unique - a landmark, one-off sample library consisting of a signature string sound never before available. Captured at Abbey Road's Studio Two, the most famous recording room in the world, Iconic Strings is steeped in a rich musical history and is just waiting to become part of your compositions.

Iconic Strings captures 5 of the world's best players, recorded by GRAMMY-winning engineer Sam Okell (The Beatles - Remastered) using a mouth-watering array of beautiful microphones and recording equipment from the studio's impressive collection. This is your chance to compose using the illustrious and historic Abbey Road signal path, which has featured in countless recordings both classic and modern. Stunning mixes give you professional, broadcast level performances with groundbreaking, instant playability plus creativity and control.

## QUICK SPECS

### MAC SYSTEM REQUIREMENTS

Mac OS X 10.13 to OS X 12

Minimum: 2.8GHz i5 minimum (quad-core), 8GB RAM.

Recommended: 2.8GHz i7 (six-core), 16GB RAM.

M1 Apple computers are supported and 64 bit DAW required. (32 bit DAWs not supported).

To use the multi-voice arranger:

Minimum: Intel Core i7 (or Xeon from mid 2015 models or newer) \*Older CPUs will require to increase the DAW buffer sizes or limit voices.

### PC SYSTEM REQUIREMENTS

Windows 7, Windows 8, or Windows 10 (latest Service Pack, 64-bit)

Minimum: Intel Core 2.8GHz i5 (quad-core) or AMD Ryzen 5, 8GB RAM

Recommended: Intel 2.8GHz i7 (six-core) or AMD R7 2700, 16GB RAM

To use the multi-voice arranger:

Minimum; Intel Core i7 7th gen and later or AMD Ryzen 7 2700X \*Older CPUs will require to increase the DAW buffer sizes, or limit voices.

- Download Size 293GBs
- Disk space required during install: 293GBs

# WELCOME

The Professional edition of Abbey Road Two: Iconic Strings offers 12 signals including 2 modern mixes, 2 vintage mixes and 8 microphone positions for full control. Professional users can customise even further, diving into the Abbey Road mic cupboard to really hone your sound, covering all the essential positions and more, captured using rare, vintage mics including the very same Neumann u47s, KM54s and M50s used on those iconic sessions from the 60s and many more.

If the walls of Studio Two could talk, they would speak of all the musical advances made in this magical space. Studio Two has a history like no other, and continues to influence the music industry after almost a century of work. It comes as no surprise that Studio Two remains one of the most in-demand recording venues in the world, a hallowed space where some of the most legendary artists, engineers and musicians have produced the most inspiring albums and scores of our times.

From the beginnings of stereo and the big bands of the '30s and '40s, to the swinging '60s, and standout pop recordings from The Beatles, Pink Floyd and Shirley Bassey, through to Kate Bush and Oasis, and more modern acts like Dave, Adele, Frank Ocean, Woodkid, Radiohead, Wolf Alice and Kanye West. Also the scores for AAA film, TV and games, from world famous composers like Alexandre Desplat, Anne Nikitin, Carter Burwell, Steven Price and Kazuma Jinnouchi have all etched themselves into the illustrious history of Abbey Road's Studio Two.

The unique sonic fingerprint of Studio Two simply cannot be replicated elsewhere due to its combination of controlled acoustics and one-of-a-kind equipment, refined over 90 years of innovation. From the vintage J37 tape machine to the dizzying array of microphones, this is the first time the sought-after signal path has been made available in a virtual string instrument.

Abbey Road Two: Iconic Strings delivers a selection of modern and vintage microphones and mixes engineered by Grammy-award-winning engineer Sam Okell. The Vintage mixes capture what many music lovers think of as Studio Two, recorded using the vintage REDD desk, parallel compression from the RS124 and all passed through the J37 tape machine. This chain was inspired and influenced by the iconic Studio Two recordings using this exact one-of-a-kind equipment.

Abbey Road Two: Iconic Strings captures the sounds of five of London's top string players (V1, V2, Va, Cello, Bass) down to the tiniest detail. The library offers music makers the choice between highly detailed composition and easy-to-use technology that assists in the writing process. A brand-new feature — the Arranger — offers a curated approach to writing with ensemble techniques. It gives composers a newfound freedom to control the instrument voices/ranges within the string band, helping them to arrive at a more tailored performance with ease.

Another intrinsic part of Iconic Strings is the all-new legatos programming. Incredibly detailed and of the highest quality, these legatos represent a significant step forward in quality and realism, building on Spitfire Audio's 15 years of experience in sampling.

Both editions include Slurred legato and a Performance legato (including Slurred, Alt Attacks and Fast Runs). The Performance legatos offer an intuitive and expressive playing experience, allowing for more emotive lines while being highly detailed and versatile. In addition Iconic Strings Professional features a Portamento legato, an expressive transition sound made famous on Oasis' Whatever.

# DOWNLOADING & INSTALLING

Thank you for buying Abbey Road Two: Iconic Strings Professional. If you are new to Spitfire Audio you can get up to speed here: <https://www.spitfireaudio.com/about/>

First though, grab the 'Spitfire Audio App' from this link, this app will enable you to download the library: <http://www.spitfireaudio.com/info/library-manager/>

## THE SPITFIRE AUDIO APP

When you launch the app you will be prompted to login using the same details you use at our site. Then you'll see the page pictured below:

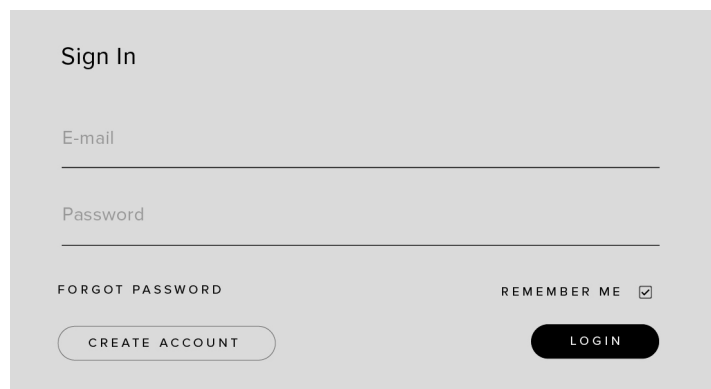

**1. TABS** the default tab is My Products, which shows all of the libraries on your Spitfire Account. Downloads will show currently downloading products.

**2. FILTERS** Clicking these filters will quickly display products you've yet to install, those already installed, and any available updates. Clicking again will remove the filter.

**3. LIBRARY** All libraries and plugins in your collection will appear with their artwork on the My Products tab. Clicking this artwork will open the product page. This is a great place to find information such as system requirements and instructions as well as Reset and Repair options.

**4. INSTALL/UPDATE** buttons allow you to quickly start a download directly from the My Products tab, instead of clicking through to the Library. Next to the button the size of the download is shown.

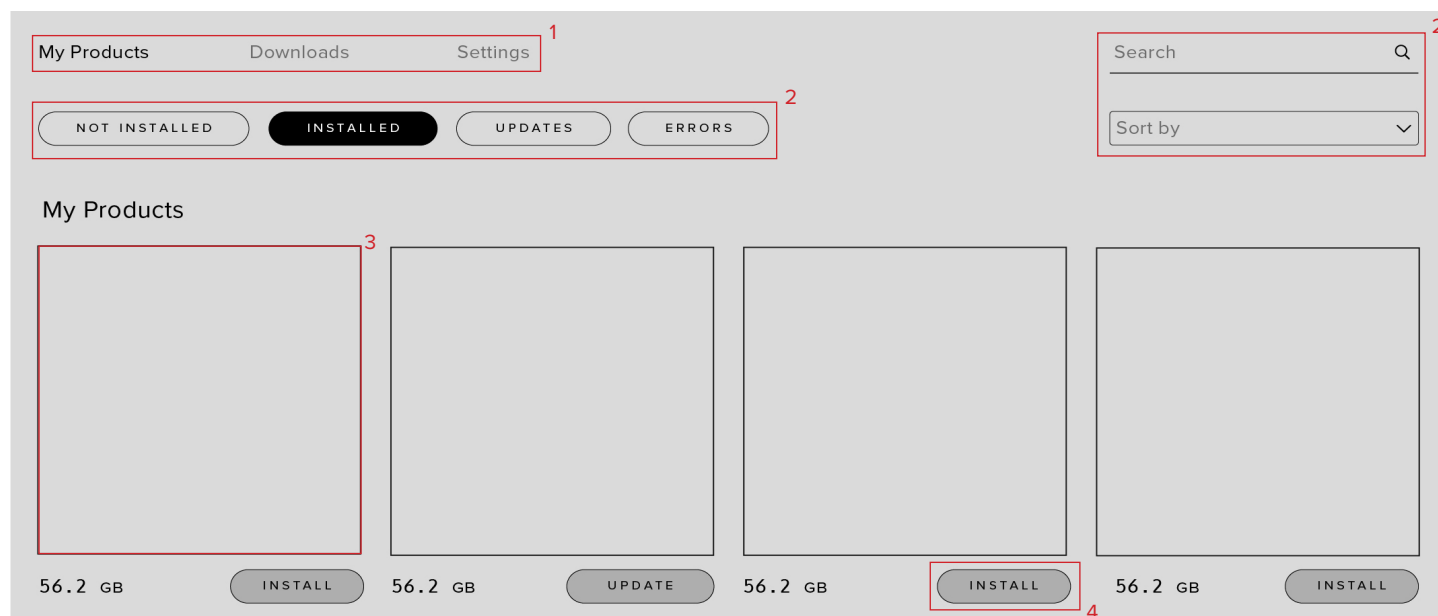

# THE SPITFIRE APP PREFERENCES

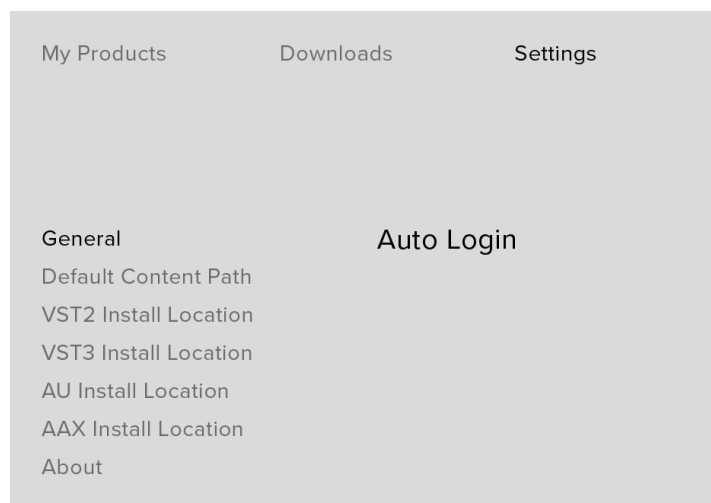

If this is your first time using the Spitfire Audio App for a download you may wish to first navigate to the Settings tab. Here you can set the Default Content location for where you wish to download your libraries. You can also you can set the default VST2 install location to the folder where your DAW expects to find VST files.

Here you can also enable Auto Login to save time in future.

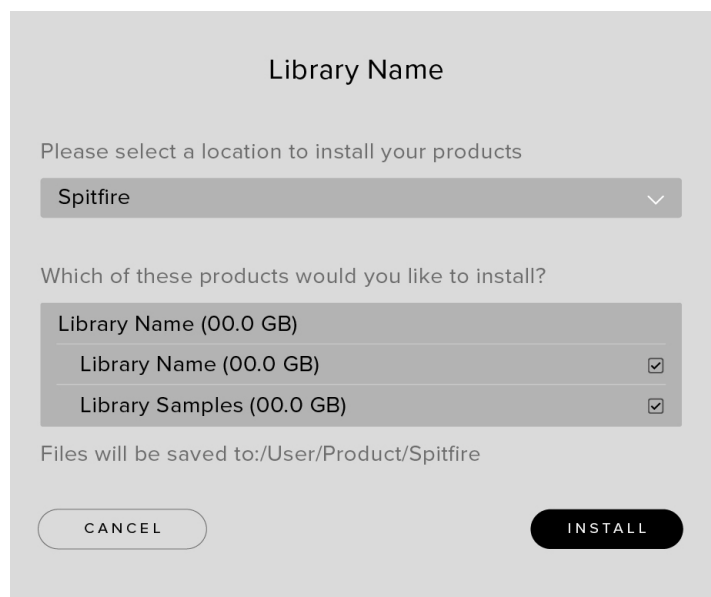

Once you are happy with your preferences, click the Install button for the library. This is either directly on My Products tab under the library artwork, or it can be found by clicking on the library image and clicking the install button on the page that appears.

Clicking either of these will prompt you for a location, the default content location in your preferences will be suggested but you can select any suitable location. If installing from a hard drive, ensure that you choose the drive as the location.

Once you are happy with the location click Download.

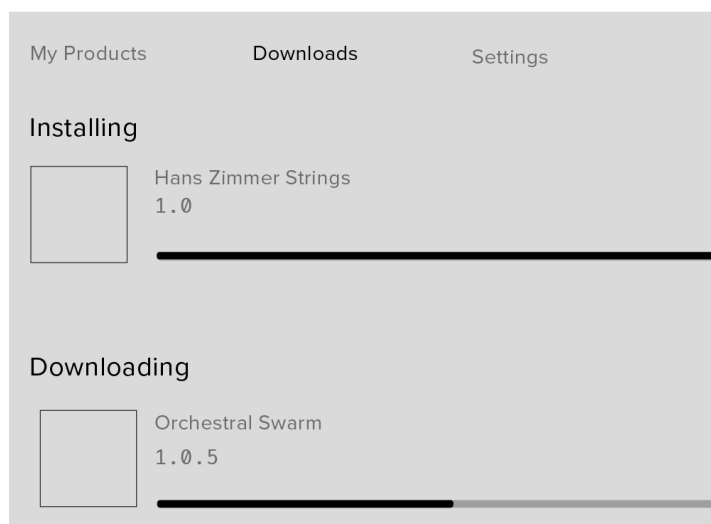

After clicking install you will be directed to the Downloads tab where you can watch the progress if you like. You can of course leave the Downloads tab and start other downloads but at this point you should leave the Spitfire App open until the download completes.

# THE DEDICATED PLUGIN

Abbey Road Two is its own, self contained plugin built for VST, AU and AAX, so once you've downloaded and installed you're ready to go.

## LOGIC PRO X

- On a fresh project, a track dialogue box will automatically pop up
- Choose 'Software Instrument', and then look beneath the 'Instrument' dropdown
- Select AU Instruments > Spitfire Audio > Abbey Road Two.

## CUBASE

- Right-click the track window and choose 'Add Instrument Track'
- Underneath the 'Instrument' dropdown, choose Abbey Road Two
- Select 'Add Track'

## PRO TOOLS

- Go to the 'Track' menu at the top of the screen, and select 'New'
- In the pop-up, select Stereo and Instrument Track, and press 'Create'
- In the first Insert slot, select multichannel plug-in and 'Instrument'
- You should see the Abbey Road Two available as an option

# HAVE A LOOK AROUND

## THE ABBEY ROAD TWO INTERFACE

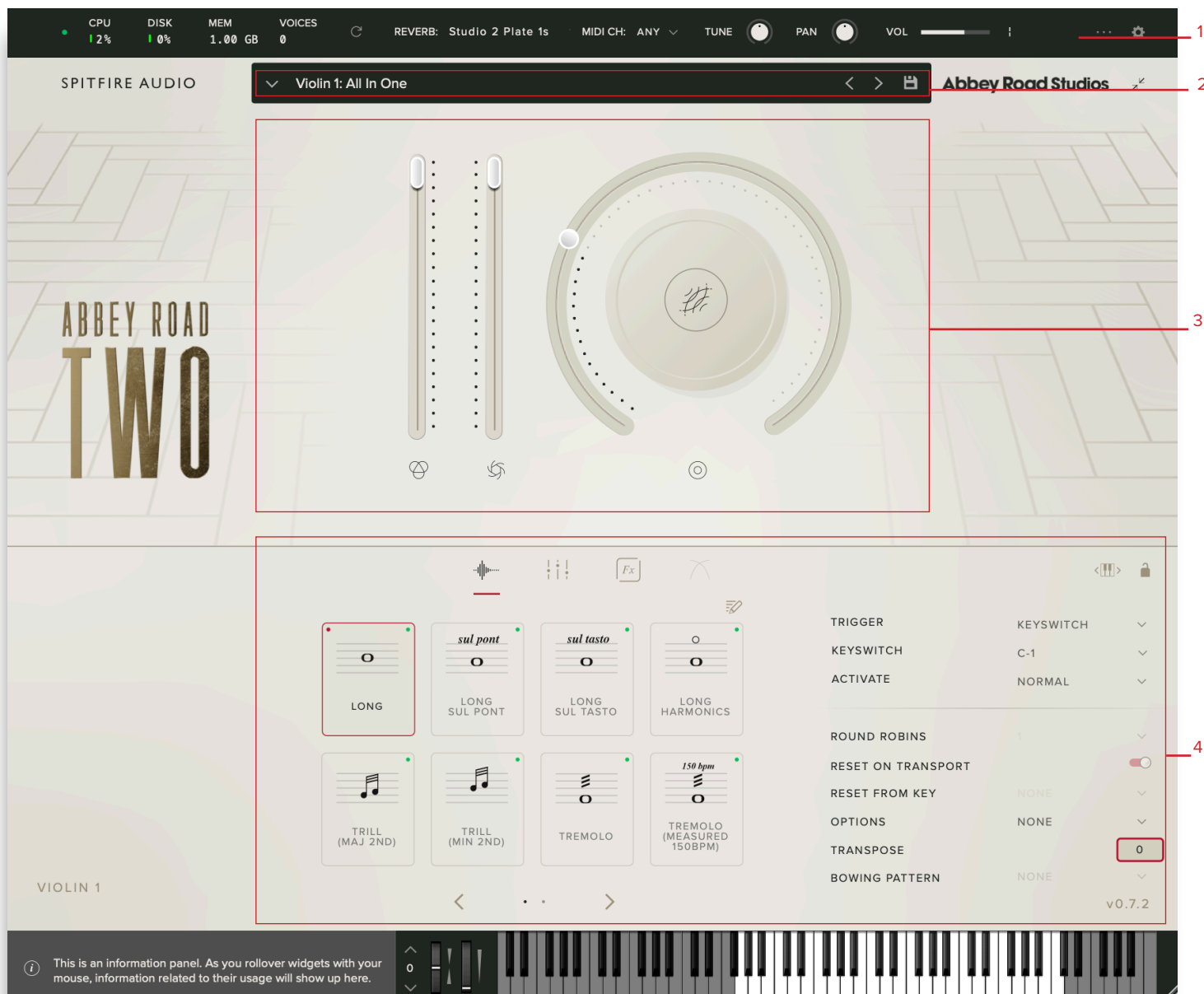

## OPENING YOUR FIRST PRESETS

When you first open Abbey Road Two, this is what you will see.

### 1. TOP MENU

### 2. PRESET SELECTOR

### 3. MAIN CONTROLS

### 4. TECHNIQUE SELECTOR



## SIGNAL MIXER

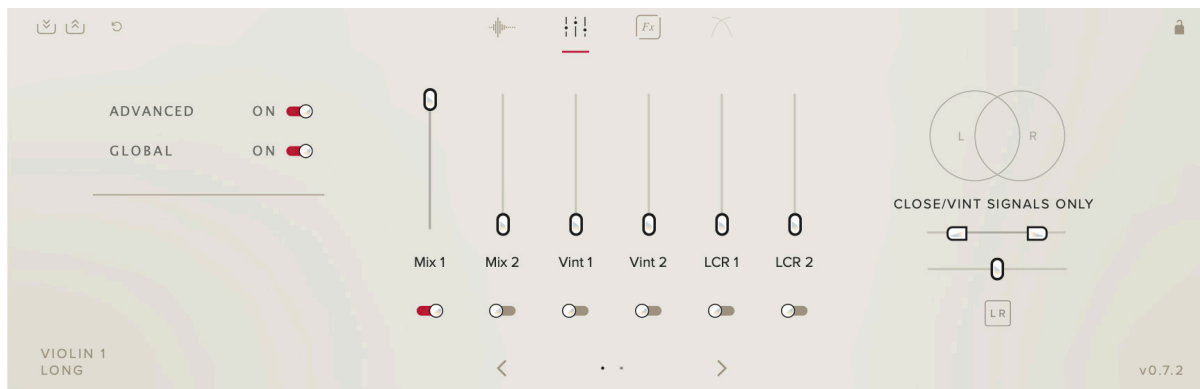

## CONTROLLERS

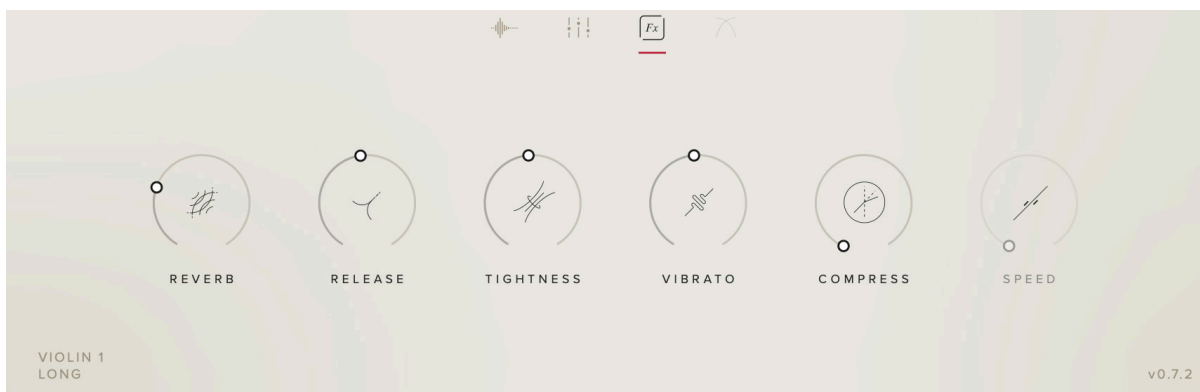

## ARRANGER

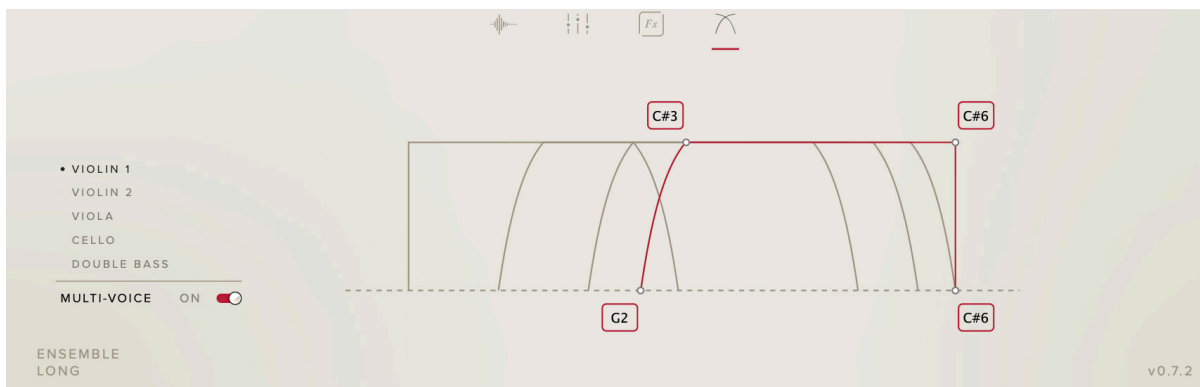

## KEYBOARD & INFO



# PRESET SELECTOR

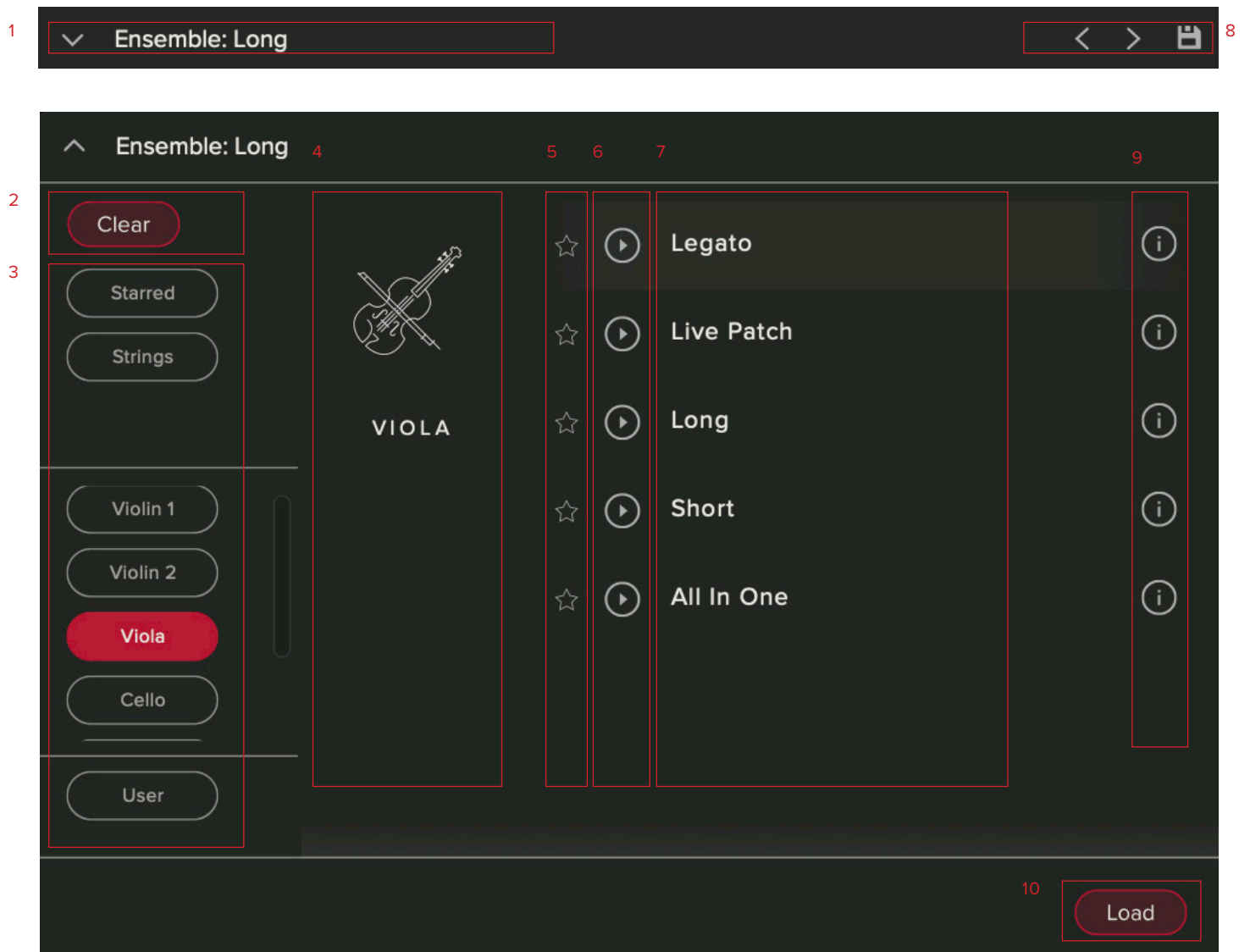

## 1. PRESET NAME

Here you can see the currently selected preset.

## 2. CLEAR FILTERS

Click here to show all instruments at once.

## 3. FILTERS

Click on a filter to only show those preset grouped by the filter.

## 4. INSTRUMENT GROUP

As you scroll through the available presets, the instrument group is displayed here.

## 5. STAR

Favourite to add to the “starred” filter.

## 6. PREVIEW

Play back a short example of the preset without having to load it. Enormously helpful when choosing a sound.

## 7. PRESET LIST

Scroll through the list of presets here. Double-click to load a preset or click the 'Load' button.

## 8. NEXT, PREVIOUS AND SAVE

With the presets view collapsed, you will be able to see the Next, Previous and Save icons.

Next and Previous will send you to the next available preset - if you have a filter enabled, you will scroll through the filtered set of presets.

Save allows you to save your own preset, click save, name the preset and it will appear under the "user" filter.

## 9. INFORMATION

Hover over on the "i" icon to see some information about the preset.

## 10. LOAD

Select a preset and then press "load" (or double-click the preset).

# MAIN CONTROLS

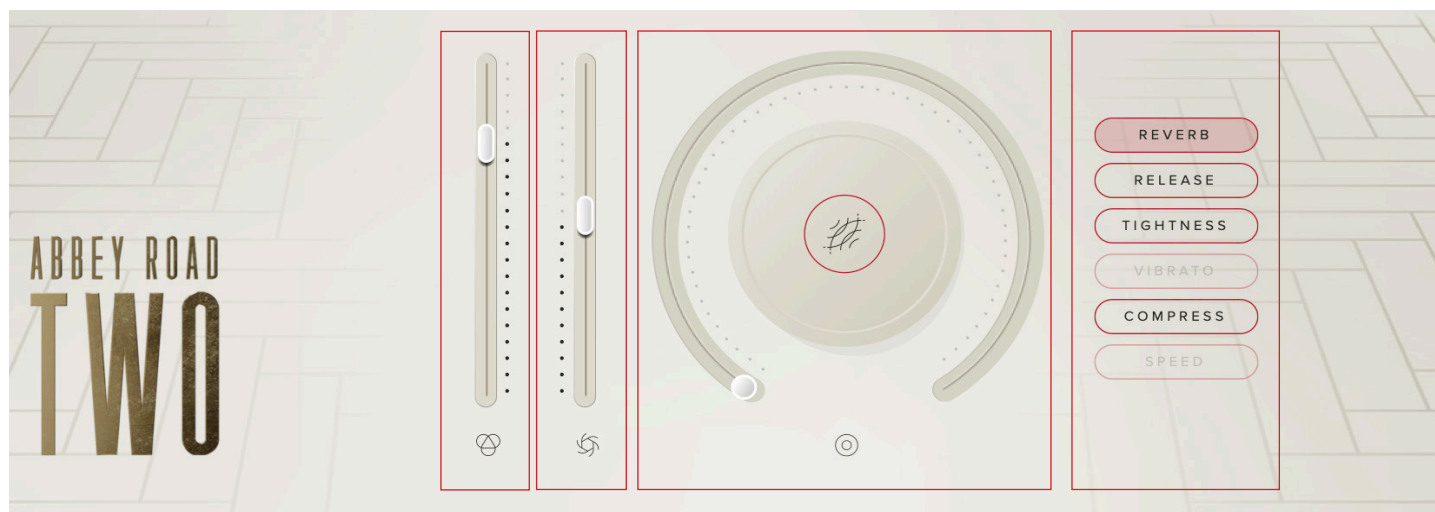

1

2

3

4.

## 1. VOLUME

Often referred to as “Expression” in our Kontakt Libraries, this is a simple level control for you to adjust along with...

## 2. DYNAMICS

Adjust the dynamic layer that you are playing here, use in conjunction with the volume to make your performances sound so much more musical.

## 3. KNOB

The configurable knob allows you to control any of the other available parameters for the particular technique.

Hover over the knob and it will turn red.

## 4. CLICK

Click and you will be able to assign any of the remaining available controls to the knob.

Right click on any of these controls to assign them to a MIDI controller. Remember that if you assign a MIDI controller to a parameter via the knob, the MIDI controller will follow the parameter rather than being permanently assigned to the knob.

Reverb: Increase to add reverberation to the sound.

Release: Extend the ends of long articulations to help blur between notes.

Tightness: Increase to eat into the sample start point. Useful for tighter passages for a more snappy response.

Vibrato: Only available for long techniques. Crossfade across three layers of Vibrato.

Compress: Controls the amount of compression.

Fixed Attack:	1ms
Fixed Release:	50ms
Fixed Ratio:	2/1

Speed: Controls how much of the Legato transition is heard. When at its slowest, the transition delays up to 150ms.

# SIGNAL MIXER

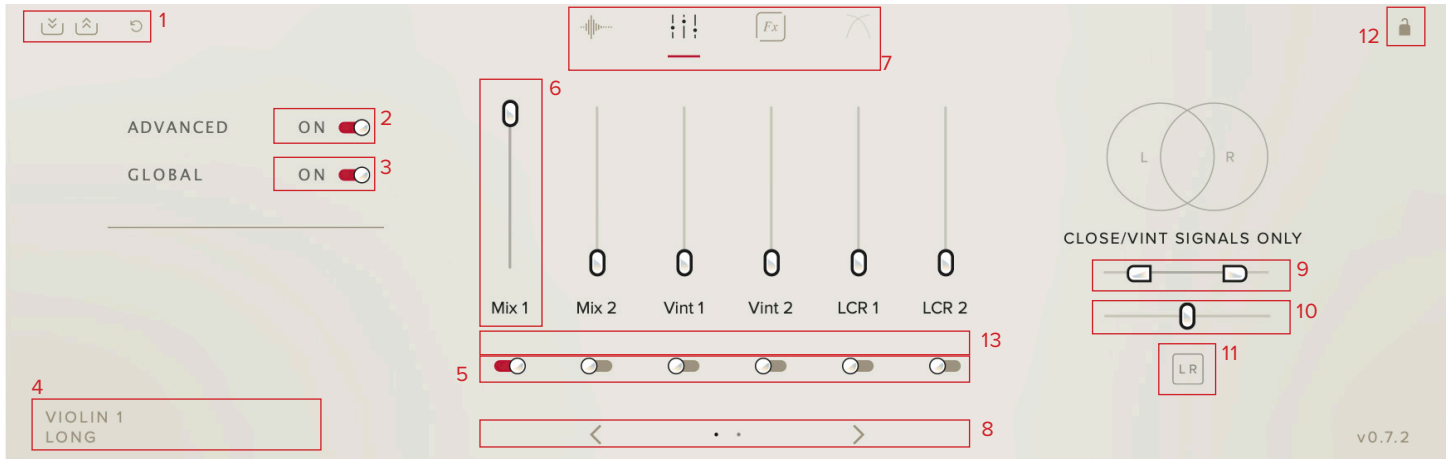

## 1. MIXER PRESETS

Load and save your own mixer presets here, this is a good way for you to share your mixes across different instruments and presets. Click on the down arrows to save and the up arrows to load.

To rename a preset after saving or delete a preset, browse to Abbey Road Two > Presets > Mix in the finder and edit the .mpreset files.

## 2. ADVANCED

By default, the mixer will load up in the advanced view, toggle off for the simple view.

In this view, you can adjust how close the instruments sound with a single fader. Under the hood, this will adjust the Close, LCR 1 and Ambient signals.

## 3. GLOBAL

This is on by default meaning that any changes you make to the mixer will affect all techniques in the preset. When switched off any changes to mixer will only affect the technique you have selected.

## 4. TECHNIQUE NAME

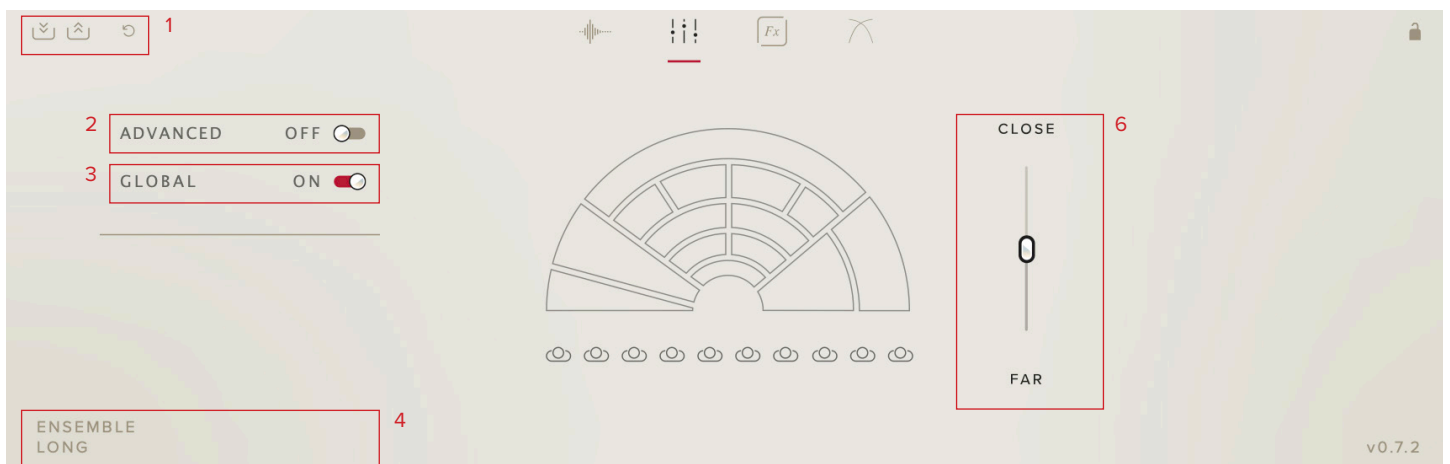

## 5. SIGNAL ON/OFF

Here you can turn signals on or off (you can also turn them on by fading them up). If you turn a signal on, pay attention to the LED in the top left of Abbey Road Two, if it is flashing red, it means that the samples are still loading into RAM and you should wait before playing again to avoid glitches.

## 6. SIGNAL FADER

Adjust the level of each signal here, right-click to learn MIDI cc# automation.

## 7. VIEW SELECT

Choose between the Technique Switcher, Mixer, Effects and the auto arranger. The Technique Switcher, Effects and Auto Arranger are covered in the following chapters of this manual.

## 8. SIGNAL NAVIGATION

Click the right arrow to access additional signals. Unused signals are greyed out.

## 9. STEREO WIDTH

Adjust the stereo width of the close and vintage signals here. Right-click to assign to a MIDI cc#. Affects Close and Vintage signals only.

## 10. PAN

Adjust the position of the close and vintage signals within the stereo field. Affects Close and Vintage signals only.

## 11. INVERT

Click to swap the left and right channels.

## 12. LOCK

Click to lock the Mixer. This will prevent further changes to the mixer, useful if you're happy with what you've done and don't want to accidentally change it. This will even prevent changes made by MIDI controllers, but beware, as soon as you unlock the mixer, the control will be active.

## 13. MULTIPLE OUTPUTS

This option becomes visible if a multi output version of the plugin is enabled in your DAW.

This is where you can assign each signal to a different stereo output.

# TECHNIQUE SELECTOR

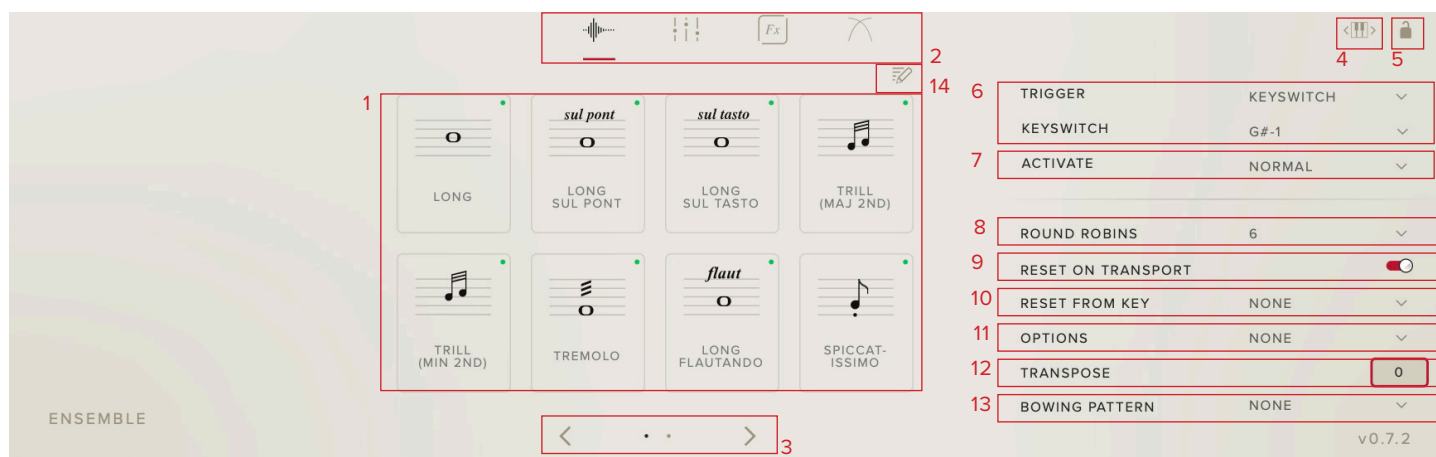

## 1. TECHNIQUE SWITCHER

Click to select a technique. Shift-Click to select multiple techniques. The red dot in the top left shows which technique(s) will play, the black outline shows which technique will be affected by any changes you make to the other options in this page.

## 2. VIEW SELECT

Choose between the Technique Switcher, Mixer, Effects and the auto arranger. The Technique Switcher, Effects and Auto Arranger are covered in the following chapters of this manual.

## 3. TECHNIQUE NAVIGATION

This option is visible when more than 8 articulations are available. Click the right arrow to access additional techniques.

## 4. KEYSWITCH ADJUST

Click and drag to move the keyswitches to the left or right on your keyboard.

## 5. LOCK

Click here to lock off the technique section and prevent any unwanted changes.

## 6. TECHNIQUE TRIGGER

With the technique trigger section you can choose to trigger techniques using various parameters:

**KEYSWITCH:** Pick a key on the keyboard that will select this technique. The selected keys will show up in green for unselected techniques and in orange for selected techniques.

**CC RANGE:** Choose a CC# and a range of values (or a single value) for the control that you want to trigger this technique.

**VEL. RANGE:** Switch technique based on how hard you are playing. You might want to trigger longs when playing softly and pizzicato when playing hard.

**MIDI CHANNEL:** Switch techniques based on the incoming MIDI channel.

**SPEED:** Switch technique based on the speed of playing. Specify the time interval between notes to switch to a particular technique.

## 7. ACTIVATE

Choose between “NORMAL” and “LATCH” for your technique switching.

A “normal” keyswitch will change articulation and remain on the changed articulation until the next keyswitch is pressed.

Latch will switch articulation until the keyswitch note is released. On release, the keyswitch returns the original articulation.

## 8. ROUND ROBINS

Round robins are a way to ensure that repeated notes don't sound robotic and unnatural. We record the same note multiple times and then cycle through them. Here you can choose to reduce the number of round robins that are being used.

## 9. RESET ON TRANSPORT

If you're worried about the effect of the round robins making each run through of your session sound different, you can choose to reset the round robins using the DAW transport.

## 10. RESET FROM KEY

You can also reset the round robins using a keyswitch. Choose that keyswitch here.

## 11. OPTIONS

**NEIGHBOUR ZONE RR:** Double the number of round robins by “stealing” notes from neighbouring notes and transposing them to match the pitch.

**LAYER X2:** Thicken the sound by layering round robins on top of one another. This option will play round robins 1/2 followed by 3/4, effectively halving the number of round robins.

**LAYER X2 (NO SKIP):** Same as above but this time you will be playing 1/2 followed by 2/3 and so on, meaning that you will not halve the number of round robins available.

**LAYER +2:** This option will play the round robins from the tone above the key played but transposed down so that it plays at the right pitch.

**LAYER -2:** This option will play the round robins from the tone BELOW the key played but transposed UP so that it plays at the right pitch.

## 12. TRANSPOSE

Transpose the instrument up or down in 1 semitone increments. This control does not stretch the samples, but instead transposes the incoming MIDI notes. To adjust samples, use the tune knob explained on page [21](#).

## 13. BOWING PATTERN

Available for all short Spiccatisissimo, Spiccato and Staccato only.

Bowing Pattern provides the ability to alternate the direction the bow is moving on each Round Robin. Choose from 6 different options or none.



U = Upbow, times the number shown.

D = Downbow, times the number shown.

## 14. TECHNIQUE EDITOR

Opens the Techniques Editor, allowing you to customise and edit your preset (see [pg. 20](#)).



# EFFECTS



## 1. VIEW SELECT

Choose between the Technique Switcher, Mixer, Effects and the auto arranger. The Technique Switcher, Effects and Auto Arranger are covered in the following chapter of this manual.

## 2. TECHNIQUE NAME

## 3. REVERB

You can add additional reverb to the sound here.

## 4. RELEASE

Allows you to change the amount of release trigger you hear. This only applies to Long techniques.

## 5. TIGHTNESS

The start of a short note is often not the start of the 'sound' of the instrument.

This control cuts further into the note to make it tighter but can detract from realism

Many users turn up the tightness when recording in MIDI notes, turning it back down and using a negative delay on the track in the DAW for tighter timing.

## 5. VIBRATO

Crossfade across three layers of Vibrato. Only available for Long techniques.

## 7. COMPRESS

Controls the amount of compression.

Fixed Attack:	1ms
Fixed Release:	50ms
Fixed Ratio:	2/1

## 8. SPEED

Controls how much of the Legato interval heard. When at its slowest, the transition delays up to 150ms.

# ARRANGER

Only available for Ensemble patches.

The Arranger allows you to control which instrument plays which note range when using Ensemble patches. This can be done in either a single voice or multi voice manner.

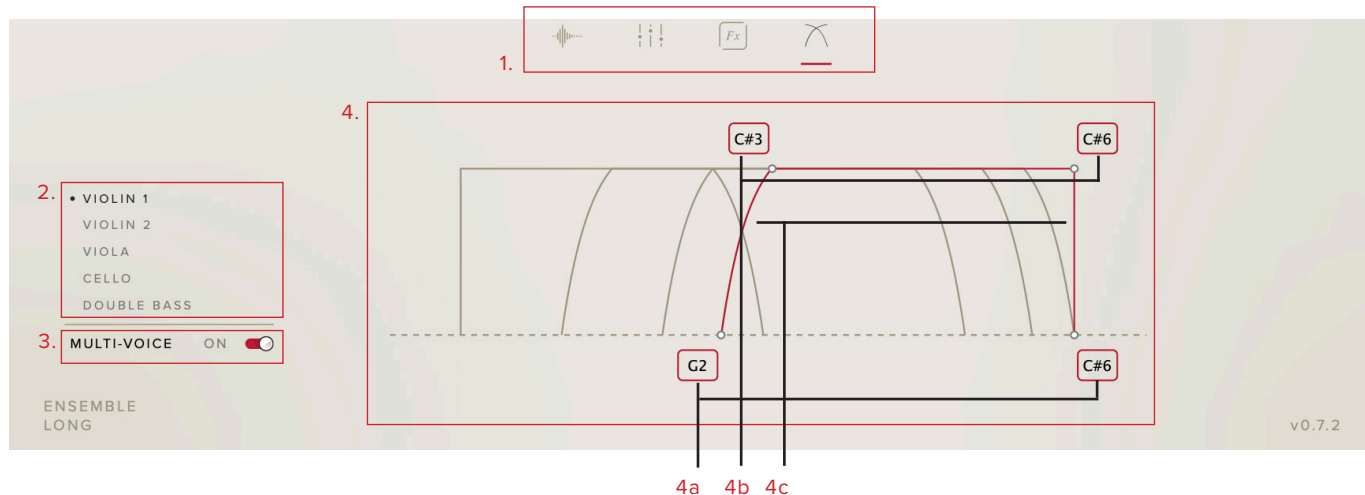

## 1. VIEW SELECT

Choose between the Technique Switcher, Signal Mixer, Effects and Arranger.

## 2. INSTRUMENT SELECT

Choose the instrument you wish to adjust the playable range of. Select before adjusting the arranger controls.

## 3. MULTI-VOICE

When turned off, each individual instrument is monophonic,

When turned on, the patch is fully polyphonic.

### MONOPHONIC NOTE PRIORITY

Each instrument V1, V2, V1a, Vc and Cb can only play one “logical” note at a time.

If the instruments are set up with overlapping regions in the arranger such that multiple instruments could play a particular note then notes are chosen using a priority order.

Each instrument has some “substitute” instruments. This means other instruments within the ensemble borrow the key range of the original instrument and optionally transpose up or down by one or two octaves.

The priority order is shown on the below:

	C1	G1	C2	G2	C3	G3	C4	G4	Clipped Hi Key
V1									
V2									
V1a									
Vc									
Cb									
V1-V1a									
V1-Cb-24									Note 43(G)
V1-Vc-12									
V2-V1a									
V2-Cb-24									Note 43(G)
V2-Vc-12									
V1a-Cb-24									Note 43(G)
V1a-Vc-12									
Vc-V1a+12									
Vc-V2+24									
Vc-V1+24									

The key ranges depicted in the diagram are just for illustration purposes.

V1 and V2 are deliberately set differently to aid this illustration

*MONOPHONIC NOTE PRIORITY cont...*

Reference the graph [Page 18](#) and imagine a note “coming in” at the top and falling down through the table.

The first coloured block it reaches for an instrument not already playing “wins” the right to play the note.

If V1 is already playing and note G4 is played the priority becomes V1-V1a so the V1a plays it. But if the V1a was already playing then it would be passed to the Cb and transposed down by 24 semitones. If Cb was already playing then the Vc transposed down by 12 semitones would play it.

One exception is that the Cb never plays as a substitute instrument above note 43 (G) so Cb will often be skipped in the priority order in favour of Vc.

## 4. RANGE CONTROLS

**4A RANGE LOW/HIGH:** Set the lowest and highest note of the playable range for the selected instrument.

**4B ROLL- OFF LOW/HIGH:** Set the note that the instrument is scaled from.

**4C DYNAMIC SCALING:** The steepness of the curve indicates a bigger dynamic drop.

# TECHNIQUE EDITOR

In the Technique Editor you can remove and reorder techniques from the current preset.

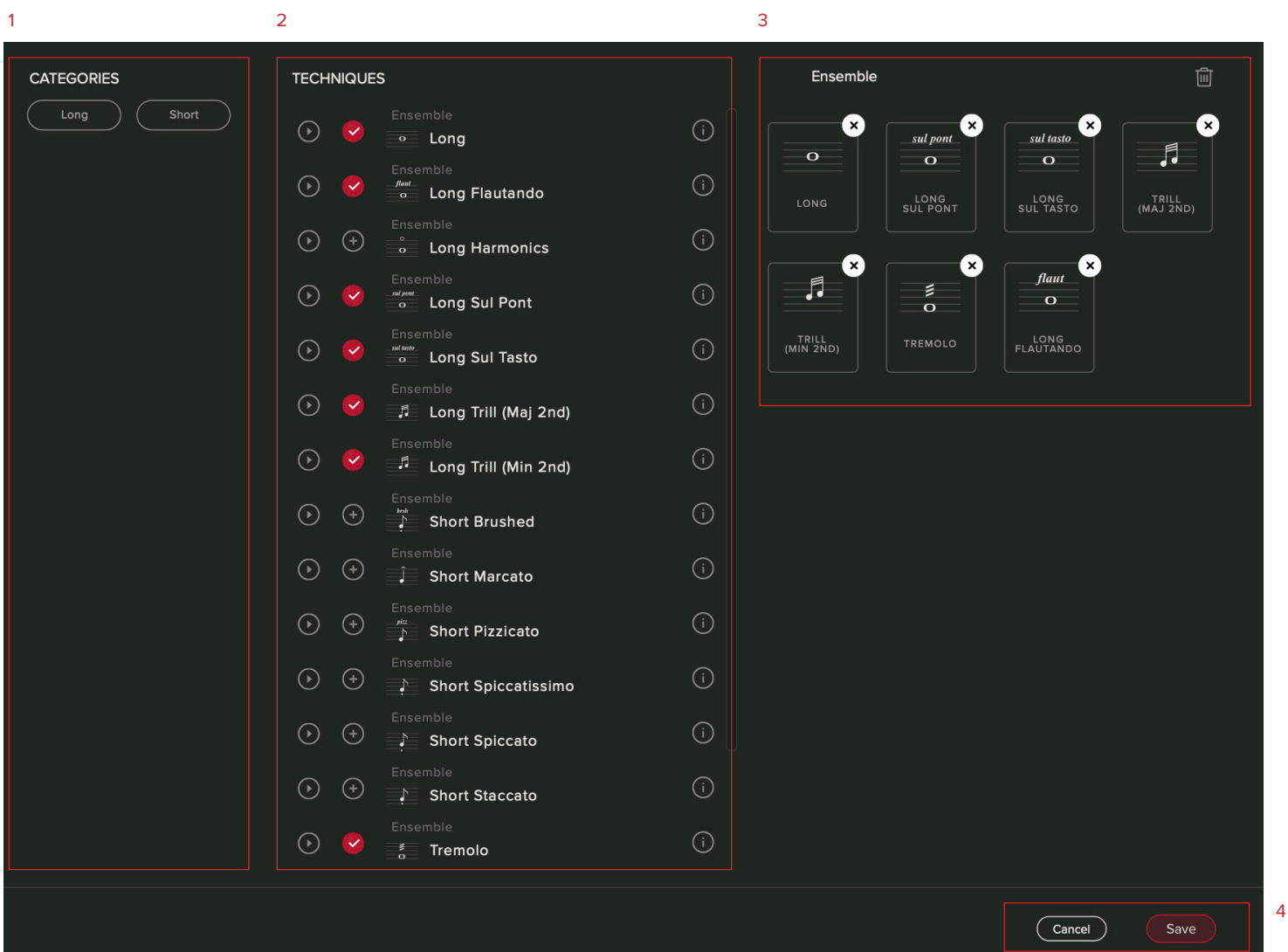

## 1. CATEGORIES

The Categories panel allows you to filter between all available techniques for this specific preset.

## 2. TECHNIQUES

The central 'Techniques' panel shows all available techniques for each preset. Click the '+' to add techniques back into your current preset.

## 3. TECHNIQUES ARRANGER

The panel on the right is where your current articulations are displayed. Click and drag these to re-arrange the order. Clicking the 'x' in the top right corner deletes the technique. Click the 'trash-can' in the upper corner to remove all techniques completely in a single click.

## 2. CANCEL / SAVE

Once you're done, click 'Save'. If you have made a mistake and don't want to save, choose 'Cancel' instead to go back to your previous settings.

# TOP MENU



## 1. LED

Shows when an instrument is loaded by lighting solid green. If this flashes, your instrument is not fully loaded.

## 2. CPU METER

An indication of how much your CPU is being taxed, the green flash next to the CPU meter will turn red when you are overloading it.

## 3. DISK METER

How hard your hard drive is working. If this is close to, or going over 100% it's time to consider a faster drive.

## 4. MEMORY

This shows how much RAM you are currently using in this instance of Abbey Road Two. While the preset is loading, this will show the instrument loading into memory.

## 5. VOICES

Shows how many voices are being used at any one time.

## 6. REFRESH

Refresh the instrument, alt-click to refresh the whole plug-in. This can be useful if you have hanging MIDI notes or have moved samples in your file system.

## 7. REVERB

Choose from 12 different reverbs curated using the Abbey Road Studio 2 Plates and Chambers. Use the Large Hall Impulse to blend with Abbey Road ONE.

## 8. MIDI CH

Set the MIDI channel that will control the instrument here. If in doubt select "any" so that the instrument will react to any incoming MIDI messages.

## 9. TUNE

Move this knob to tune in increments of 0.01 of a semitone. CMD/CTRL-click to reset to default.

## 10. PAN

Pan the signal left / right. CMD/CTRL-click to reset.

## 11. VOLUME

Control the overall volume of the instrument.

## 12. LEVEL

A visual indication of the level of the instrument.

## 13. PRESET SETTINGS

### A. VELOCITY MAPPED TO DYNAMICS

Different behaviours for the Dynamics fader.

- 1) Full Velocity Range.
- 2) Velocity Mapped to Dynamics.
- 3) Compressed Velocity High.
- 4) Compressed Velocity Low.

These settings will change how hard you need to hit the keyboard to trigger different layers. Velocity mapped to dynamics will allow you to control short note velocity with the mod wheel.

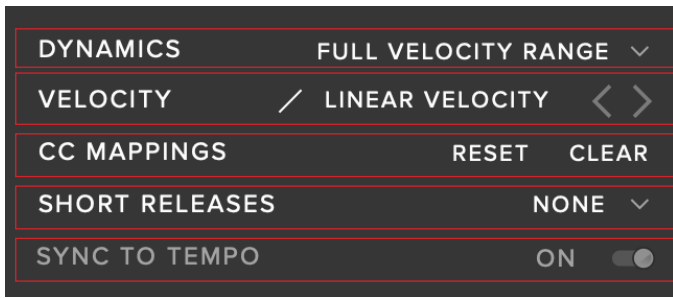

A  
B  
C  
D  
E

## B. VELOCITY

Pick from 4 different velocity curves to suit your controllers touch.

## C. RESET AND CLEAR CC MAPPINGS

Clicking reset will set all of the CC mappings for this instrument to the defaults - useful if you've got yourself in a mess!

Clear will remove all CC mappings on the plugin.

## D. SHORT RELEASES

Alter the release trigger behaviour.

Timed releases play a release trigger and cut off the original sample if the note on/off duration is less than 300ms.

Untimed releases plays the release regardless of time.

## E. SYNC TO TEMPO

Sync to your host BPM. This works for the measured termolo articulations.

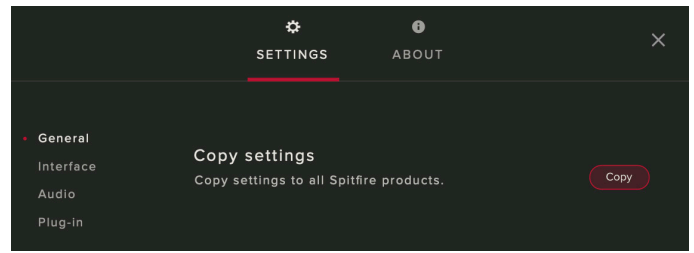

## 14. PLUGIN SETTINGS

### COPY SETTINGS

Common controller values will copy to other Spitfire plugins.

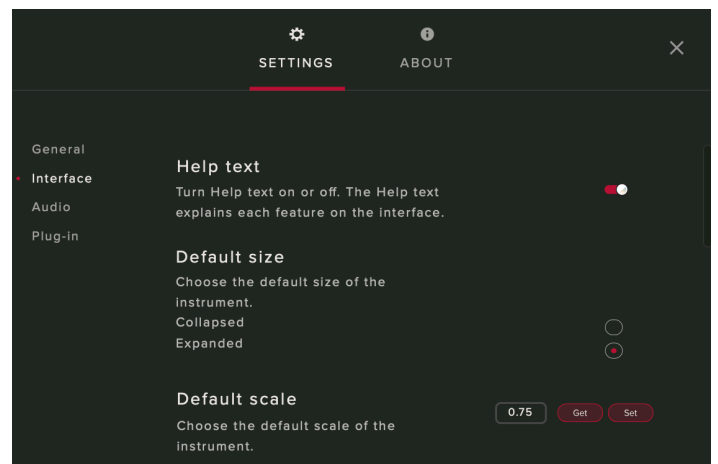

### HELP TEXT

Turn this on to display parameter information in the bottom left corner of the plug in.

### DEFAULT SIZE

Set whether the instrument opens up collapsed or expanded by default.

### DEFAULT SCALE

How big the plugin UI is when opened. Press "get" to set the current scale or type a value before pressing "Set" and "Save"

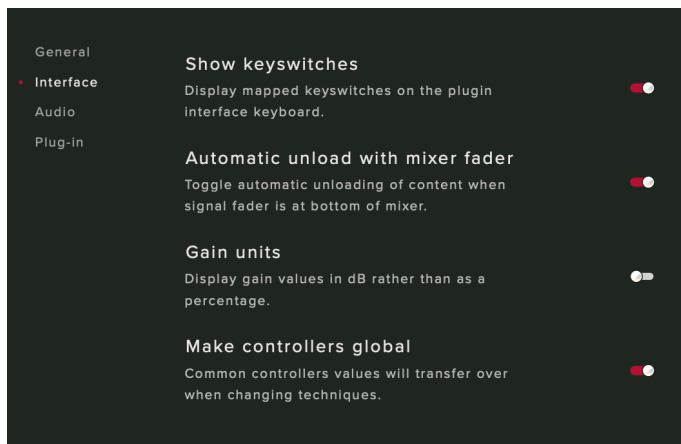

## SHOW KEYSWITCHES

When this option is on, presets that have multiple techniques will show available keyswitches in red and the currently selected technique(s) in yellow.

## UNLOAD WITH MIXER FADER

Toggle this to unload data from RAM when fader is pulled down to the bottom.

## GAIN UNITS

Toggle this if you want your gain to be displayed in dB instead of as a percentage.

## MAKE CONTROLS GLOBAL

Common Controller values will remain when switching techniques.

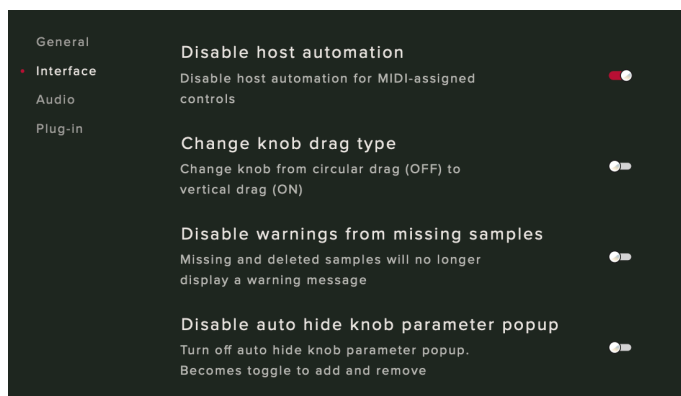

## DISABLE HOST AUTOMATION

Turn this on to enable the Host Automation from the DAW.

## CHANGE KNOB DRAG TYPE

Change the mouse behaviour when dragging the Knob control.

## DISABLE WARNINGS FROM MISSING SAMPLES

Hide an error in the plugin top left corner which is visible when the library is missing its content.

## DISABLE AUTO HIDE KNOB PARAMETER POPUP

When enabled, clicking the knob will always shows the fx controls menu.

## ENABLE AUTOMATIC EXCLUSIVE MIC GROUP BEHAVIOUR

Disable if you want mics to be un grouped together.

For example, when enabled, enabling the ambient mic, will disable the Pop mic grouping.

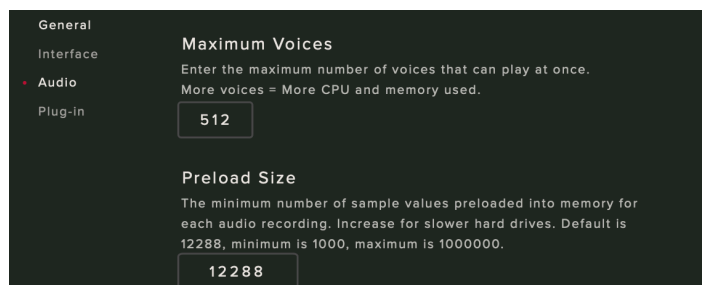

## MAXIMUM VOICES

Enter the maximum number of voices that can play at once. More voices = More CPU and memory used.

## PRELOAD SIZE

The minimum number of sample values preloaded into memory for each audio recording. Increase for slower hard drives. Default is 12288

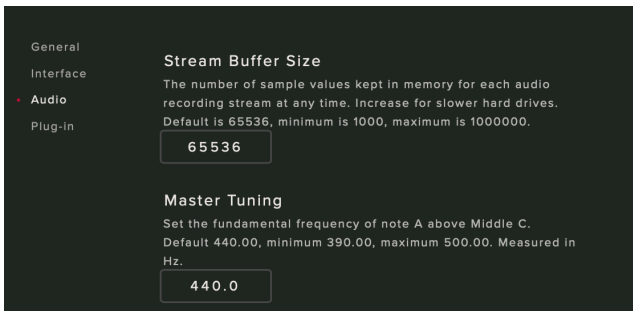

## STREAM BUFFER SIZE

The number of sample values kept in memory for each audio recording stream. Increase for slower hard drives.

## MASTER TUNING

Change the default tuning of the plugin. For example A = 440hz or A = 432 HZ.

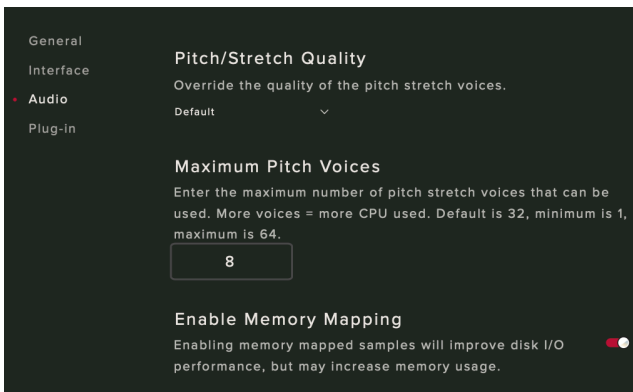

## PITCH/STRETCH QUALITY

This option allows you to override the default pitch/time quality to improve performance or improve audio quality. Not used in this library at this time.

## MAXIMUM PITCH VOICES

Limit the number of voices triggered at any one time. Lower values can aid CPU.

## ENABLE MEMORY MAPPING

Turn off for windows machines for better performance

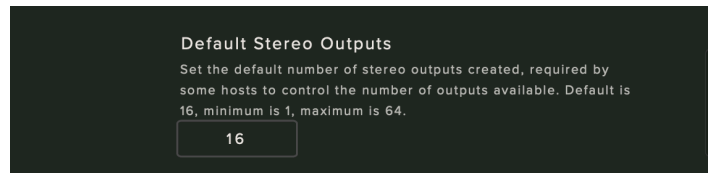

## DEFAULT STEREO OUTPUTS

The default number of outputs for the Microphone routings.

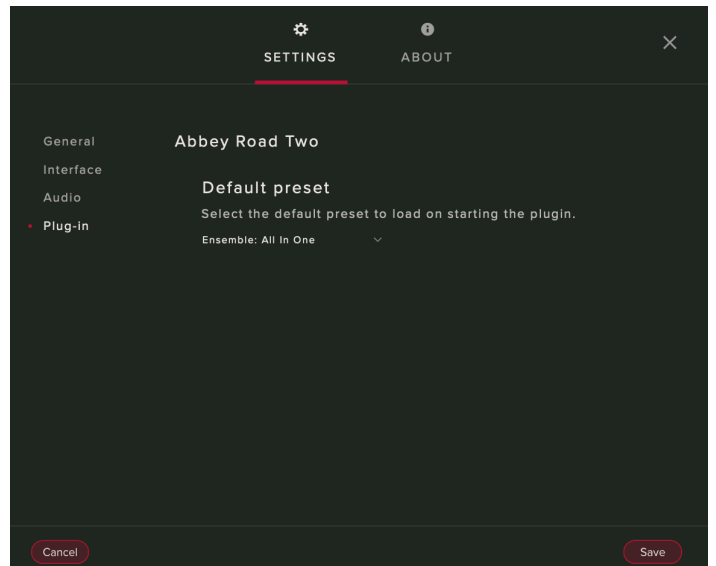

## PLUGIN

Under this heading you can choose a default preset to load, click on the preset name and choose your preferred preset from the list.



# MICROPHONE SIGNALS

## MIX 1

A tight mix of the Close Condensers and LCR 1. Perfect for song writing and general purpose.

## MIX 2

A mix with more room, formed of the Close Ribbons, LCR 2, Stereo Mid and Ambients. Suitable for hearing slightly more of the room.

## VINTAGE MIX 1

A vintage mix using Abbey Road's vintage REDD desk, parallel compression from the RS124, all passed through the J37 tape machine.

## VINTAGE MIX 2

An alternative to Vintage Mix 1, with added Automatic Double Tracking for a distinctly Beatles / Walrus effect.

## LCR 1

Similar to a Decca Tree position but better matched to the ensemble size in the room.

3x M50s in an Left, Centre, Right formation

## LCR 2

This position is less focussed than LCR 1 as the the 3x REDD 47 Mics are positioned in Omnidirectional mode, giving more sense of space.

## CLOSE CONDENSER

The signal placed closest to each instrument. The condenser spot mics, use for a close, full sound.

KM86 Violins, KM140 Viola, FET47 on VC and CB.

## CLOSE RIBBON

Identical to close condenser, except this time using Ribbon Mics. 4038s for each instrument.

## CLOSE VINTAGE

The third and final close position using the vintage spot mics, as used on iconic Studio 2 sessions, placed according to vintage recalls.

KM54's positioned close on Violins 1, 2 and Viola.

U47 positioned close on Cello and Bass.

## ST RIBBON

Positioned below and in front of LCR 1.

This signal is a Royer SF24 (XY) giving a warmer, more focussed sound than the LCR 1 signal whilst retaining the stereo image.

## ST MID

Similar to ST RIBBON but placed slightly closer to the ensemble. This time positioned using the ORTF position. The mics used were SCHOEPS MK21's giving a brighter tone. Useful for a different perspective of the quintet.

## AMBIENT

Two omnidirectional microphones placed towards the rear of the room, spaced 2m apart.

Great for use in a 5.1 surround mix, or to add more space to a stereo mix.

# MICROPHONE GROUPING

The Microphone Groups are as follows:

GROUP					
A	MIX 1	-	-	-	-
B	MIX 2	-	-	-	-
C	VINTAGE 1		-	-	-
D	VINTAGE 2		-	-	-
E	ALL CLOSE	ST RIB	ST MID	AMBIENT	

A group will become active when it has all its signals enabled. This is shown below for Group A.

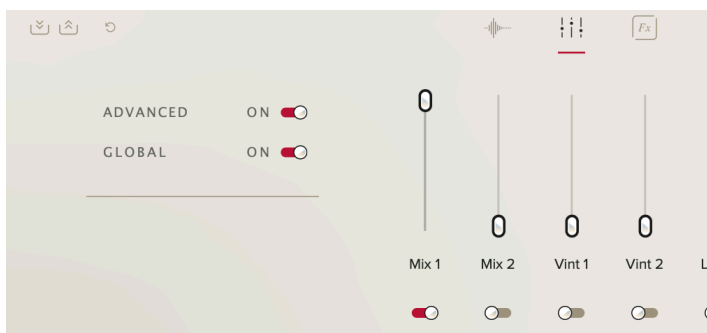

You can tell which are enabled by looking at the active switches below each signal.

If you then turn up any signal from a different Mic Group, for example VINT 1 from Group C, it will automatically disable any other group. In this case, Group A: Mix 1.

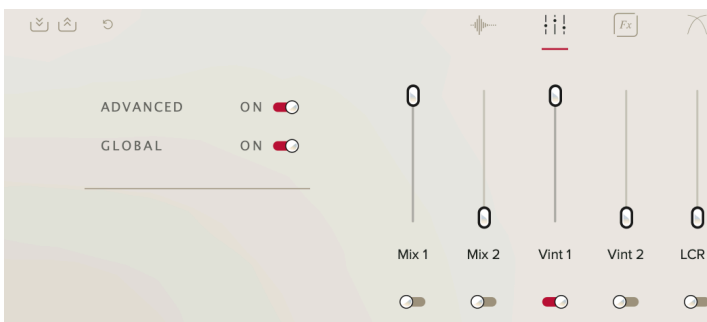

This setting can be turned off under plugin settings, interface.

# TECHNIQUES

## LEGATO (8VE (8VE)

Legato in the context of a sample instrument refers to a technique of capturing the sound of an instrument moving from one note to the next. Capturing this detail gives a lot of added realism, but means that you need to play monophonically (one note at a time).

To 'trigger' the in-between sounds, you must make sure that you hold down the first note while pressing the key of the second note. As long as you overlap the notes in this way, the engine will know that you want to trigger what we call a 'legato transition'.

### LEGATO INFORMATION

CC1 Dynamic peak points:

ff - 127 (100%)

mf - 88 (70%)

pp - 38 (30%)

## INTERVAL TYPES

Portamento (Only available in Pro)

Slurred

Fast Runs

Portamento transitions occur between Velocities 1-19 and overlapping the MIDI notes.

Slurred transitions occur between Velocities 20-127 and overlapping the MIDI note,

The speed control changes all interval types so you can go from 100ms (responsive) to 150ms (more latency but sounds more natural)

## RUNS

At very fast speed only. Timed between 100ms and 150ms based on the speed slider.

## LONG

The most vanilla of the long notes; a standard sustained note. This is the basic playing style, recorded both with and without vibrato.

### LONG SUL PONT

Short for 'sul ponticello', meaning to play on the bridge. Here the players bow very close to the bridge, which produces a brittle and edgy sound. Always reminds us of nails on a chalkboard!

### LONG SUL TASTO

To play with the bow over the fingerboard, producing a thinner and more delicate tone.

This is different from Flautando, in that it is not specifically required to be 'flute-like', and therefore is more of a soft and delicate, yet still 'normale' sounding tone.

### LONG HARMONICS

If a player holds down lightly on the string a perfect fourth interval up from the note they are fingering, you hear what is called an 'artificial harmonic' sound - two octaves up from the note being fingered.

This is called 'artificial' to distinguish it from the natural harmonic series of the open string. These 'natural' harmonics can be heard by moving the finger up and down the string while lightly bowing. Available as both short and long techniques.

### TRILL MIN / MAJ 2ND

A trill is where a player alternates between two notes. These work great as accented performance embellishments, or you can play them very softly to create unique and interesting textures.

## TREMOLO (UNMEASURED)

A Tremolo is where a player rapidly moves the bow whilst keeping the left hand on the same notes. The effect is a shimmering one when played soft, and a very aggressive and tense sound when played loud.

## TREMOLO (MEASURED)

“Measured” refers to the technique being recorded to BPM. This library has two Tremolo techniques measured to 150BPM and 180BPM.

## LONG FLAUTANDO

This refers to a soft ‘flute-like’ way of performing on a stringed instrument. Often the bow will be near or over the fingerboard, which gives off a very different character to the sound from the usual bow position.

## SPICCATISSIMO

The shortest in duration of the short notes. Similar to the more traditional Spiccato, just shorter.

## SPICCATO

Shorter than Staccato, the Spiccato technique captures a very ‘tight’ sound with the bow bouncing off the string quickly.

## STACCATO

Staccato in notation refers to a ‘shortened and detached’ style of playing. In the case of samples, this usually refers to a single but defined short note.

## MARCATO

Played with a very heavy and accented abrupt start to a note. Great for layering, or for extra bite in a phrase.

## BRUSHED

Similar to a Staccato, however has a more gentle bowing technique which extends the note out.

More suitable for Baroque music.

## PIZZICATO

Plucking the strings with the finger.

## LIVE PATCHES

A playable combination of long and short sounds that trigger differently depending on the playing style.

# APPENDIX A — FAQS AND TROUBLESHOOTING

## Q: WHAT ARE THE SYSTEM REQUIREMENTS?

### MAC SYSTEM REQUIREMENTS

Mac OS X 10.13 - OS 12  
Minimum: 2.8GHz i5 (quad-core), 8GB RAM

Recommended: 2.8GHz i7 (six-core), 16GB RAM

32 bit is no longer supported. Apple Silicon / ARM is supported.

### PC SYSTEM REQUIREMENTS

Windows 7, Windows 8, or Windows 10 (latest Service Pack, 64-bit)

Minimum: Intel Core 2.8GHz i5 (quad-core) or AMD Ryzen 5, 8GB RAM

Recommended: Intel 2.8GHz i7 (six-core) or AMD R7 2700, 16GB RAM

## Q: I WANT TO RESET THE PLUGIN SETTINGS TO THE DEFAULT

You can delete the .settings file to reset the settings to default. This is located at:

Users/username/Music/Spitfire Audio - on a Mac

C:\Users\username\AppData\Roaming\  
Spitfire Audio - on a PC.

## Q: MY LIST OF PRESETS IS EMPTY, HOW DO I SOLVE THIS?

If you have moved your Abbey Road Two Library folder, you can solve this problem by using the “Locate Library” feature in the Spitfire Audio App.

If this does not solve the problem, the library likely needs reauthorising, to do this, use the “repair” feature in the Spitfire Audio App.

## Q: I SEE A RED EXCLAMATION MARK IN THE TOP LEFT OF ABBEY ROAD TWO, WHAT DOES THIS MEAN?

This means that there is an error, you can click the exclamation mark to open a log with further details. It is likely that using the “Repair” and “Locate Library” features in the Spitfire Audio App will solve the problem but if not, contact our support team at [spitfireaudio.com/support](https://spitfireaudio.com/support) and attach the log.

## Q: CAN I INSTALL ON MORE THAN ONE COMPUTER?

With our products you have two licenses. This means that you are allowed to download and install on two computers you own, say your main rig and your mobile rig. If you have purchased the library on a hard drive, you should copy the contents of the drive on to the destination machine before completing the download with the Spitfire App. If you downloaded Abbey Road Two, you can copy the library folder over to the second machine and then use the “Repair” and “Locate Library” features in the Spitfire Audio App.

## Q: I CAN'T SEE THIS IN THE KONTAKT LIBRARIES PANE AND WHEN I TRY AND LOAD IT INTO KONTAKT IT SAYS NO LIBRARY FOUND

This library does not run in Kontakt, it is a standalone plug-in that you can run in your chosen DAW.

## Q: HOW DO I AUTHORIZE ABBEY ROAD TWO ON A MACHINE NOT CONNECTED TO THE INTERNET?

It not possible to authorise Abbey Road Two on a machine not connected to the internet. Authorisation is done with the Spitfire Audio App and an internet connection is required.

## Q: HOW CAN I REDOWNLOAD A PRODUCT?

This can easily be done via your Spitfire Audio App. To reset both your entire library download or the latest update;

- Open up the Spitfire Audio App and log in with your account email and password.
- Select the product artwork you wish to re-download
- On this page is a “cog wheel”. Select this, choose “reset” from the menu. Then “Reset Entire Download” (for a full download) or (Latest Update) for the latest update.

This will reset your latest update ready for install again. You can repeat this process for any of the libraries you own.

Note that there is a limit to how many times you can reset your downloads in a certain time frame. If you do exceed your reset limit please get in touch.

## Q: DIFFICULTIES IN DOWNLOADING / INSTALLING

Customers may find that they have some difficulties in the downloading process. If you find that you are having some trouble, please check the list below for possible causes:

- The formatting of your drive, if it is FAT32 this will cause errors, because there is a maximum file size with this format of 4GB and our download files will exceed this limit. To solve this problem, reformat your drive or use a different drive. We recommend NTFS on PC and Mac OS Extended on Mac. Other possible issues:

- Spitfire App freezes in the “Extracting” stage for hours. This may be because our libraries are often very large files, and this is the stage where the compressed files are extracted and placed in their final locations on the hard drive. There could be hundreds of GB of content to unpack, so it really can take hours. If you’re unsure whether it has crashed or is extracting files, visit

the installation folder you chose when you started the install. If everything is working normally you’ll see various files appearing in the folder (or one of its sub-folders).

- If your download gets stuck and is continually cycling and not resuming, please get in touch with us, giving us as much detail as possible about your set up. It would be helpful if you can tell us your operating system, where you are downloading from (your country, and also whether you’re at home or work), your ISP, and whether there are any proxy servers or firewalls between your computer and the internet.

## Q: I HAVE FAST INTERNET, WHY IS MY DOWNLOAD SLOW?

We have no direct influence on your actual download speeds, our libraries are hosted on Amazon S3 servers which are normally very quick but it may well be that at certain times of the day when traffic is particularly busy, your ISP may throttle your connection speeds.

We would advise you to leave your download running overnight as speeds should ramp up at less busy times. Our Spitfire App downloader aims to use as much of the available bandwidth as possible to give you the quickest possible speeds, and may take several minutes to reach its peak.

## Q: CAN I TRY BEFORE I BUY?

No - it is not currently possible to demo our products.

If you go to our Youtube channel you’ll see many walkthroughs containing detailed info about all our products -- you can hear them being played in real time with no smoke and mirrors!

## Q: MY LIBRARIES ARE NOT SHOWING UP IN MY SPITFIRE APP

A handful of customers may find that when they log into their Spitfire App, some of their previously purchased products do not show up in the 'Installed' section or in the 'Download Ready' section either. It may be that you have purchased these under another email address. Checking other possible email addresses for your previous purchases may help to find these missing products. If this is not the case, and these missing products were purchased a few years ago, please create a support ticket telling us your account email address, and any serial numbers you may have to go with these missing products. Our support team can also merge one or more accounts together if you'd like to consolidate all your purchases in one place.

The more information we have, the quicker we can get you back up and running!

## Q: HOW DO I UPDATE MY PRODUCTS?

The main premise of downloading our products is that our Spitfire App downloads into the folder you choose, so it is important to choose the folder above where you want the download to go. The best file path for our products is something very simple, a long file path will cause errors as there is a character limit on how far the Spitfire App can read. We advise a file path of something along the lines of: Samples Drive > Spitfire Audio

When it comes to downloading / updating - if you have a folder called 'Spitfire Audio' always point the Spitfire App to the folder Spitfire Audio - never go into this folder and choose the actual library in question.

## Q: HOW DO I REDOWNLOAD THE LATEST UPDATE?

With the continuous improvements to our Spitfire Audio App, we have incorporated the ability to reset your own downloads.

This can easily be done via your Spitfire Audio App.

Open up the Spitfire Audio App and log in with your account email and password.

- Select the product artwork you wish to re-download
- On this page is a "cog wheel". Select this, choose "reset" from the menu. Then "Reset Entire Download" (for a full download) or (Latest Update) for the latest update.
- This will reset your latest update ready for install again.

You can repeat this process for any other updates you wish.

If you do not see the option to reset your download in your Spitfire Audio App, we would advise to download the latest version of the Spitfire App from [spitfireaudio.com/info/library-manager/](http://spitfireaudio.com/info/library-manager/).

## Q: I'VE BEEN WAITING AGES FOR MY DOWNLOAD LINKS?

We run all our orders through a fraud checking process. The automatic fraud check takes 20 minutes (but can take up to an hour during a very busy period, eg. Black Friday) If your order gets caught at this stage, we run a manual order check, and this can delay the processing of your order for up to 24 hours.

You should however receive an order confirmation email IMMEDIATELY upon placing your order. This confirms that your order has successfully been logged in our system and that your payment was successfully taken. Please check your junk folders before contacting our support.

## **CAN I DOWNLOAD ON A PC, THEN TRANSFER TO A MAC OR VICE VERSA?**

Yes, you can copy the library folder and plugin files over to the second machine and then use the “Repair” and “Locate Library” features in the Spitfire Audio App. Please note that although the majority of the download can be done on a separate machine, you will always need an internet connection to finish the authorisation process.

## **Q: HOW DO I DOWNLOAD PRODUCTS ON MAC OSX 10.9?**

The version of the Spitfire App needed to install Abbey Road Two only supports Mac OSX 10.10 and upwards.

## **Q: I HAVE FOUND A BUG**

In some cases we can't squash them all and bugs shamefully make their way through. If you think you have found a bug, please contact us with all the relevant information;

- A description of the bug you have found
- A screencast (video) of the bug happening, or an audio example
- The exact preset name (or presets) in question and also the library giving us as much detail as possible will help us get to the bottom of the issue.

## **Q: WHAT IS YOUR REFUNDS / RETURNS POLICY?**

If you have NOT completed the download / installation process, and bought within 14 days then we CAN refund / return your product, please contact support with your account email address and order number so we can handle this quickly. If you HAVE completed the installation process (even if you've not yet registered your serial number), please see our EULA in regards to why we do not accept refunds and returns. We can refund hard drive orders up until the point when the drive is dispatched from our office. This is usually 1-2 days after you order.

## **Q: I'VE FORGOTTEN MY PASSWORD?**

If you have forgotten your password, please see this link [spitfireaudio.com/my-account/login/](http://spitfireaudio.com/my-account/login/), and click 'Forgotten Password'. If at some point in the past you asked us to merge two or more accounts but have since forgotten, you MAY find that the forgotten password isn't working for the email address you asked us to merge FROM. In this case, please contact support with your name, and any email addresses you think we might know about, and we'll work out what has happened.



# APPENDIX B — TECHNIQUES/MICS/MIXES

## TECHNIQUES

LEGATO  
LONG  
LONG SUL PONT  
LONG SUL TASTO  
LONG HARMONICS  
TRILLS MAJ/MIN 2ND  
UNMEASURED TREMOLO  
MEASURED TREMOLO  
LONG FLAUTANDO  
SPICCATISSIMO  
SPICCATO  
STACCATO  
MARCATO  
BRUSHED  
PIZZICATO

## MICROPHONES

MIX 1  
MIX 2  
VINTAGE 1  
VINTAGE 2  
LCR 1  
LCR 2  
CLOSE CONDENSER  
CLOSE RIBBON  
CLOSE VINTAGE  
ST RIBBON  
ST MID  
AMBIENT

## APPENDIX C — DEFAULT CC MAPPINGS

Dynamics	1
Global Gain	7
Global Pan	10
Expression	11
Release	17
Tightness	18
Reverb	19
Vibrato	21

© SPITFIRE AUDIO HOLDINGS LTD  
MMXXI